

CONNECTING COST EFFICIENCY AND PERFORMANCE

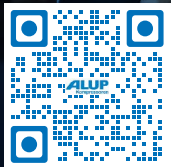

LARGO 55-90 KW
ALLEGRETTO 55-90 KW
EVOLUTO 45-90 KW
OIL INJECTED SCREW COMPRESSORS



EXPERIENCE THE NEW LARGO 55-90 KW & ALLEGRETTO 55-90 KW & EVOLUTO 45-90 KW SCREW COMPRESSORS CONNECTING COST EFFICIENCY AND PERFORMANCE

The new range offers you excellent performance, plug-and-play installation and the reliability you can expect from the ALUP brand. The advanced connectivity adds intelligence to your compressor, allowing you to decrease operating costs further while increasing productivity.

READY TO DISCOVER
OUR NEW COMPRESSORS?



↑
**IMPROVED
PERFORMANCE**

Built with the newest technology, our compressor range features IE4 motors which are the best in order to reach high performance and energy cost savings.

↑
**KNOWN ALUP
RELIABILITY**

Our range has always been valued for their excellent reliability. This is also something you can expect from the new range, plus that little bit more.

↑
STAY CONNECTED

The Airlogic²T controller gives you insight into the performance of your compressed air system – remotely and at any given moment – allowing you to make smarter use of your resources.



**YOUR PARTNER IN
SUSTAINABILITY**

We only have this one planet. That is why sustainability guides everything we do at ALUP. The innovations we develop and the products we build are geared toward reducing your energy consumption and your CO₂ footprint, and helping the environment all of us share. Supporting your sustainable operation is our number one priority.

MAIN FEATURES



New air end

- The in-house designed compression element, combined with an IE4 efficiency motor, comes with increased performance, lower compression temperature and high reliability.
- The Free Air Delivery is increased up to +4% and power consumption is reduced by up to -3% thanks to the improved product selection and our in-house designed compressor element.
- Fit for environments with ambient temperatures of up to 46°C due to superior component design.



Airlogic²T

- An intuitive and easy-to-operate control system gives you an insight into the performance of your compressed air system – remotely and at any given moment.
- Controls the unit by maintaining the pressure between programmable limits.
- Protects the unit thanks to the programmed shutdown warnings.
- Maintains the unit thanks to our programmed service time interval meter, informing the customer when service is due.



Easy installation and service

- Effortless maintenance thanks to the easily removable panels and quick access to all service parts.
- Low maintenance costs.



Silencing baffle

- Guarantees reduced noise levels.
- Even more important when operating the compressor close to the point-of-use.



In-house designed components

- The spring-controlled unloader valve includes a more precise mechanism that allows to release excess pressure in a more reliable way.



Air quality

- A water separator drain comes as standard on units with an integrated dryer.
- Removes the condensate formed in the cooler as the compressed air is cooled.
- Improves the air quality.



Integrated dryers

- The whole Industrial range is now available with integrated dryers.
- Internal Water Separator integrated in air cooler for machines with integrated dryer.



High efficiency motor

- IE4 Super Premium efficiency class.
- Oil-cooled PM – aircooled induction.
- IP66 protection against dust ingress.
- Introducing the 90kW PM machine will complete the PM range.



GENEROUS AND SMART COOLING SYSTEM

- Bigger air oil coolers have been selected, resulting in a high cooling capacity, maximum cooling efficiency and increased reliability.
- The large fan provides forced ventilation and conveyed flows, improving the air flow and reducing operating temperature for enhanced reliability.



10 REASONS TO CHOOSE ALLEGRETTO & EVOLUTO

The Evoluto and Allegretto ranges are the result of dedicated investments in R&D and in-house developed key components. By maximizing performance, energy efficiency and reliability of each individual component we have ensured that the final result is our most innovative compressor to date.

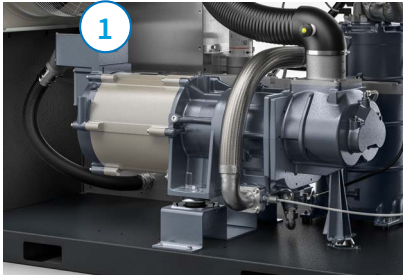

1. Interior Permanent Magnet (iPM) motor

- IE4 Super Premium Efficiency.
- Oil-cooled, optimal cooling at all speeds.
- IP66, highest possible protection against dust ingress.
- In-house designed.

2. New generation screw elements

- Superior performance and efficiency.
- Improved rotor profile, reduced pressure losses.
- In-house designed and produced.

3. Integrated dryer

(not available for Allegretto)

- Enhanced air quality
- Condensate removal at the source, minimizing pipework corrosion
- Reduced footprint, up to 1/3 of a standalone dryer
- Single service visit, reducing maintenance cost
- No installation cost

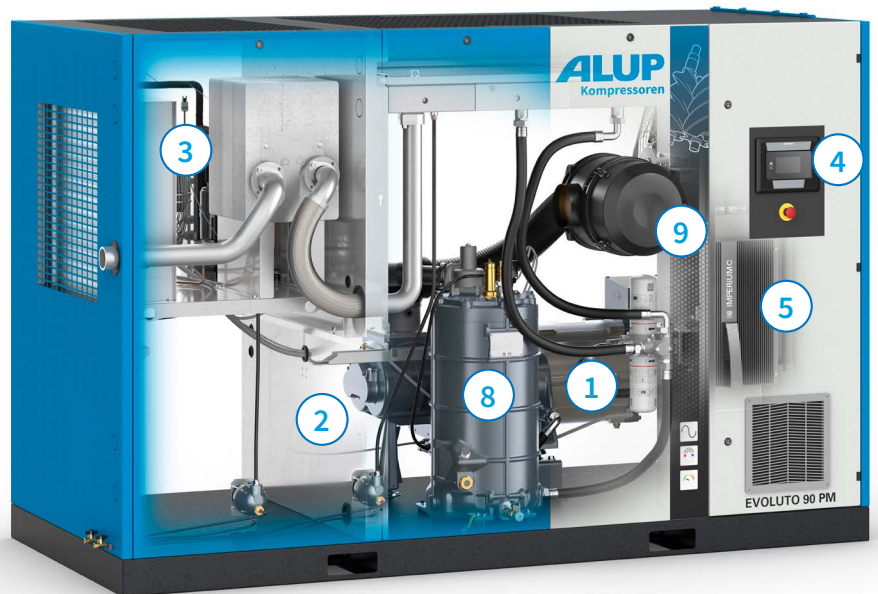

4. Airlogic² T touchscreen controller

- Easy-to-use full-color graphical display with touchscreen.
- Integrated connectivity helps optimizing and save energy.
- In-house designed.

5. Imperium - Variable Speed Technology

- Robust industrial design with IP5X protection.
- Tailor-made for screw compressor applications.
- In-house designed.



6. Proven inlet valve

- Optimizing the inlet flow to the screw element.
- Maintenance-free, low total cost of ownership.
- In-house designed.

7. Solid inlet baffle

- Filters mats pre-filter incoming air, ensuring superior air quality.
- Highly efficient and low noise axial fan as standard.



8. Casted oil separator vessel

- Integrated minimum pressure valve (MPV) eliminates risk of leakage.
- Designed for optimal oil separation and low oil carry over.

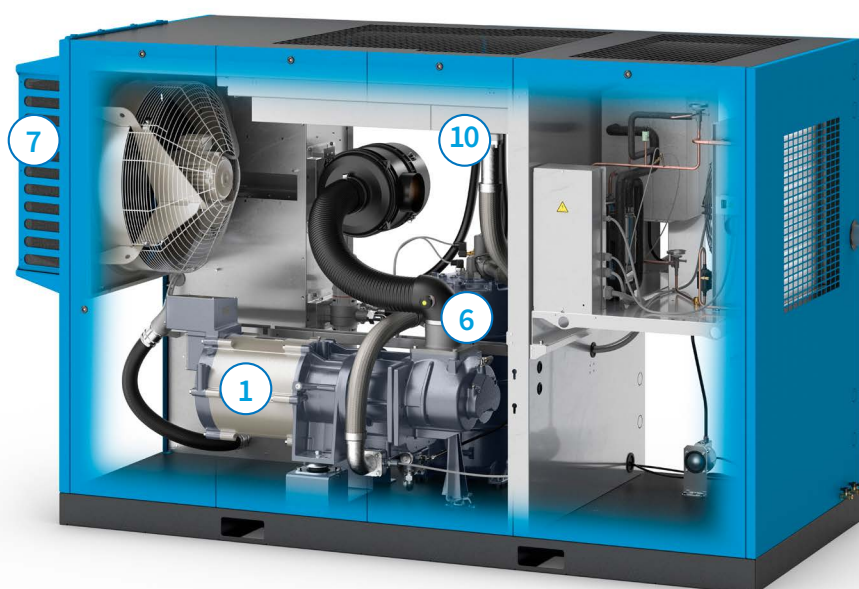

9. Quality filtration

- Protecting internal components and increasing lifetime.
- Heavy duty air/oil/oil separator filters with long lifetime for low total cost of ownership.

10. Separate coolers

- Separate oil and air cooler for high-quality cooling and long lifetime of the coolers.
- Gliding rails for easy and safe removal.
- Easy access for cleaning.
- Integrated water separation for coolers used on machines with integrated dryers.



REVOLUTIONARY DRIVE TRAIN TECHNOLOGY

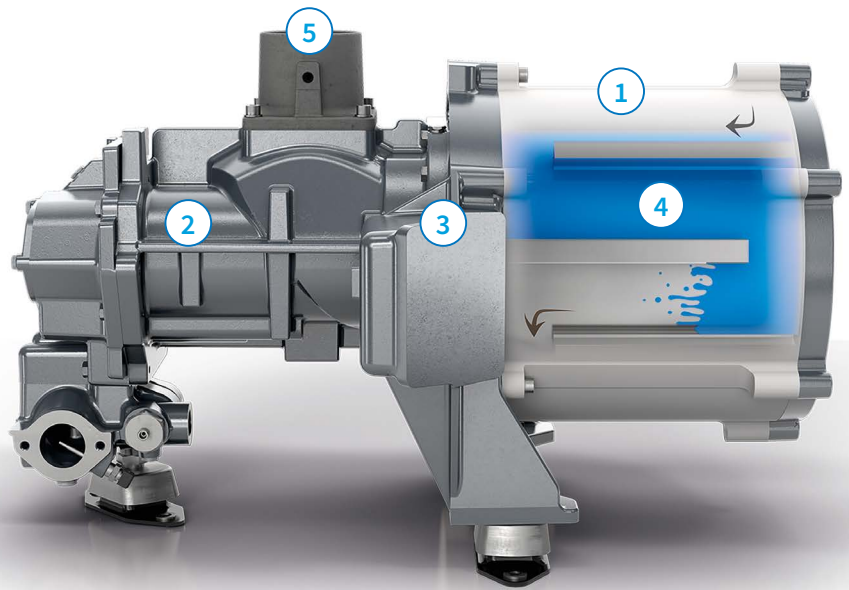

IMPROVED ENERGY EFFICIENCY SAVES YOU MONEY

- In-house designed iPM motor (1) with IE4 Super Premium Efficiency.
- New generation in-house designed screw elements (2), with improved efficiency.
- Integrated direct drive transmission (3) for minimal losses.
- Smart inlet valve (5) optimizes the inlet flow and improves efficiency.



INCREASED RELIABILITY EXTENDS LIFETIME

- iPM motor (1) rated IP66, premium protection against dust and water ingress.
- Globally renowned screw elements (2), proven in thousands of installations.
- Optimal cooling at all speeds and conditions thanks to oil-cooling principle (4) of the iPM motor (1).



MAINTENANCE-FREE DESIGN MINIMIZES DOWNTIME AND IMPROVES YOUR PRODUCTIVITY

- No (re)grease(ing) of the motor (1) bearing needed.
- Coupling-free direct drive design (3), no maintenance needed.
- Smart inlet valve (5), no maintenance needed.



A BIG LEAP IN ENERGY EFFICIENCY

WHY ENERGY EFFICIENCY?

Energy costs represent about 70% of the total operating cost of your compressor over a 5-year period.

WHY VARIABLE SPEED COMPRESSORS?

By matching the air supply to the air demand, unload losses are avoided, and energy costs reduced on average by 30%.

WHY INVEST IN EVOLUTO?

Imperium variable speed technology combined with iPM motor technology and evolved the energy efficiency of variable speed compressors to a new level, resulting in energy savings of up to 45%.



3%

Installation

77%

Energy consumption

45%

Fixed speed technology



8%

Service

12%

Investment

How much energy could you save in your existing compressor installation?

Contact us for an energy audit. We will measure the air demand and energy consumption of your existing installation and generate a detailed report at the end. Based on your specific situation we can simulate and show how much your energy costs would reduce with an Evoluto. If you would decide to invest in an Evoluto, you can expect a typical payback of 1-2 years.



EQUIPPED WITH THE AIRLOGIC²T CONTROLLER BRINGING YOU A NEXT-LEVEL, RUGGED AND INTUITIVE DISPLAY.

The new Airlogic²T is an incredible state-of-the-art compressor controller. But more than this, it means ease of use, peace of mind, and performance optimisation. In combination with our ICONS Intelligent Connectivity System, the Airlogic²T allows you to improve both the reliability and efficiency of your production process.

- BIG, EASY TO USE 4" TOUCH CONTROL WITH A SIMPLIFIED LAY-OUT
- THE COMPRESSOR IS PROTECTED WITH SENSORS TO IMMEDIATELY ALERT YOU WHEN SOMETHING IS WRONG
- CLEAR OVERVIEW OF ALL PARAMETERS AND SERVICE INTERVALS



- PLAN MAINTENANCE INTERVENTIONS AT THE RIGHT TIME, GUARANTEE SYSTEM UPTIME AND ELIMINATE BREAKDOWN RISKS
- DESIGNED FOR INTUITIVE USE IN HEAVY DUTY ENVIRONMENTS

ICONS

INCREASED UPTIME, POWERED BY ICONS

With the Intelligent CONNectivity System (ICONS), data and insights are delivered straight from your machines to your computer, tablet or smartphone.

The new range of compressors can be fully connected.



EControl6i

THE OPTIONAL ECO6I CONTROLLER ALLOWS YOU TO OPTIMIZE BOTH WORKLOAD AND ENERGY CONSUMPTION.

Do you operate more than 2 compressors? The Airlogic²T can act as a master controller thanks to its built-in **EControl6i** functionality. Reduce service costs by evenly distributing running hours over your compressors and save energy by using one pressure band for your entire compressor room.

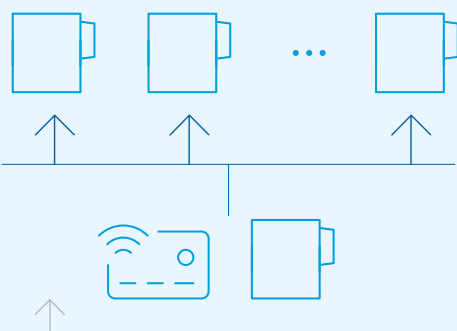

BUILT-IN OPTIONS



AIR QUALITY

Integrated water separation drains

Ensures efficient condensate removal.

Tropical thermostatic valve

For use in humid and hot conditions.

Freeze protection

Guarantees a certain oil temperature in the oil vessel to avoid condensation.

Integrated refrigerant dryer

Removes water condensate from the compressed air, minimizing the risk of product spoilage in your application.

ENERGY SAVING

Integrated energy recovery

Recovers up to 75% of the heat energy formed during the compression process, which can be used to heat up water for boilers, showers, etc.

ECO2i – ECO4i – ECO6i

Integrated multiple compressor control for up to 6 compressors reduces system pressure and energy consumption.



A RANGE OF OPTIONS

→ FULL FEATURE MACHINES

→ WATERCOOLING

→ WATER SEPARATION
DRAIN - MECHANICAL
(PACK ONLY)

→ INTEGRATED ENERGY
RECOVERY

→ OIL - 8000H OIL
SYNTHETIC

→ TEST REPORT

→ WATER SEPARATION
DRAIN - ELECTRONIC

→ EXPANSION MODULE

→ PREFILTER KIT

→ POWER DUCT
FAN - AC*

→ OIL PREHEATER =
FREEZE PROTECTION

→ OIL - 4000H OIL
FOOD GRADE

→ ECO2i

→ ECO4i

→ ECO6i

→ TROPICAL
THERMOSTAT

→ EMC FILTER

→ COMPRESSOR
RUNNING- L/
ULSIGNAL -
REMOTE CONTROL

* Not on 90kW

PERFORMANCE DATA

FIXED SPEED LARGO 55-90

Model	Max working pressure bar(g)	Reference working pressure bar(g)	Free air delivery @ reference conditions			Motor power		Noise level dB(A)	Cooling air volume m³/h	Weight		Compressed air output diameter
			m³/h	l/s	cfm	kW	Hp			STD kg	PLUS kg	
50Hz												
LARGO 55	7,5	7	626	174	368	55	75	71	10224	1308	1616	2 ½"
	8,5	8	598	166	352	55	75	71	10224	1308	1616	2 ½"
	10	9,5	536	149	316	55	75	70	10224	1308	1616	2 ½"
	13	12,5	474	132	279	55	75	70	10224	1308	1616	2 ½"
LARGO 75	7,5	7	808	224	475	75	100	73	10224	1417	1738	2 ½"
	8,5	8	779	216	458	75	100	72	10224	1417	1738	2 ½"
	10	9,5	720	200	424	75	100	73	10224	1417	1738	2 ½"
	13	12,5	622	173	366	75	100	73	10224	1417	1738	2 ½"
LARGO 76	7,5	7	901	250	530	75	100	71	10224	1521	1842	2 ½"
	8,5	8	829	230	488	75	100	71	10224	1521	1842	2 ½"
	10	9,5	763	212	449	75	100	71	10224	1521	1842	2 ½"
	13	12,5	661	184	389	75	100	72	10224	1521	1842	2 ½"
LARGO 90	7,5	7	1020	283	601	90	120	72	15336	1566	1892	2 ½"
	8,5	8	976	271	574	90	120	71	15336	1566	1892	2 ½"
	10	9,5	901	250	530	90	120	73	15336	1566	1892	2 ½"
	13	12,5	760	211	448	90	120	71	15336	1566	1892	2 ½"

VARIABLE SPEED ALLEGRETTO 55-90 & EVOLUTO 45-90

ALUP	Motor power		working pressure bar	Min. Free air delivery (7bar)			Max. Free air delivery								
	kW	Hp		7	7	7	7	7	7	9,5	9,5	9,5	12,5	12,5	12,5
	m³/h	l/s	cfm	m³/h	l/s	cfm	m³/h	l/s	cfm	m³/h	l/s	cfm	m³/h	l/s	cfm
ALLEGRETTO55	55	75	4-10bar	101	28	59	645	179	380	579	161	341	-	-	-
ALLEGRETTO75	75	100	4-10bar	97	27	57	772	214	454	714	198	420	-	-	-
ALLEGRETTO90	90	120	4-10bar	154	43	91	1041	289	613	914	254	538	-	-	-
EVOLUTO45	45	60	4-13bar	101	28	60	545	151	321	483	134	284	403	112	237
EVOLUTO55	55	75	4-13bar	102	28	60	657	183	387	573	159	337	456	127	269
EVOLUTO75	75	100	4-13bar	104	29	61	791	220	465	707	196	416	597	166	351
EVOLUTO76	75	100	4-13bar	170	47	100	936	260	551	837	232	493	689	191	405
EVOLUTO90	90	120	4-13bar	164	46	97	1037	288	610	920	256	542	745	207	438

ALUP	Noise level dB(A)	Cooling air volume m³/h	Weight		Compressed air output diameter
			STD kg	PLUS kg	
	ALLEGRETTO55	73*	10224	966	-
ALLEGRETTO75	74*	10224	995	-	2 ½"
ALLEGRETTO90	72	10224	1148	-	2 ½"
EVOLUTO45	70	8640	956	1264	2 ½"
EVOLUTO55	70	10224	966	1274	2 ½"
EVOLUTO75	72	10224	986	1307	2 ½"
EVOLUTO76	71	10224	1119	1440	2 ½"
EVOLUTO90	72	15336	1132	1458	2 ½"

* measured with optional silencing baffle

DIMENSIONS (mm)

	Length	Width	Height
Without Dryer	2135	1221	1804
With Dryer * not available for Allegretto	2979	1221	1804



ALUP'S HERITAGE

Founded in Germany in 1923, ALUP derives its name from the automotive products that were manufactured in the mechanical workshop in Köngen where the company came into existence: Auto-Luft-Pumpen. ALUP developed its first piston compressor just two years later. In 1980, rotary screw compressors were added to its product range.

The experience and expertise the company gained each year, coupled with a spirit of innovation, has led to today's high-quality product offer. The name ALUP Kompressoren has become synonymous with innovative technology blended with a strong sense of tradition. To this day, ALUP Kompressoren is operating out of the heart of Baden-Württemberg, where it all began nearly a century ago.

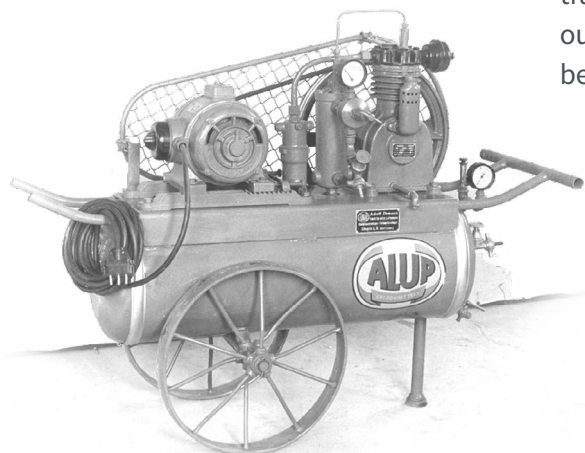

DRIVEN BY TECHNOLOGY, DESIGNED BY EXPERIENCE

Discover what happens when passion for technology meets hands-on industrial experience: designs that are easier to install and maintain, allowing you to focus on your job. Our extensive product range features the right machine for you – including the options that meet your performance requirements perfectly. High energy efficiency ensures return on investment and reduces your carbon footprint. And, because customer proximity is one of our hallmarks, you will always be one step ahead when your needs change.

1923 1925

Founded in
Germany

First piston
compressor

1980

First rotary
screw compressors

today

Innovative
technology

BECAUSE IMPROVEMENT NEVER STOPS



Contact your local ALUP Kompressoren representative

6999 6406 42



Care

Care is what service is all about: professional service by knowledgeable people, using high-quality original parts.

Trust

Trust is earned by delivering on our promises of reliable, uninterrupted performance and long equipment lifetime.

Efficiency

Equipment efficiency is ensured by regular maintenance. Efficiency of the service organization is how Original Parts and Service make the difference.

© 2024/04 Atlas Copco Airpower NV. All rights reserved.

ALUP reserves the exclusive right to modify product specifications and design without granting buyers entitlement to corresponding changes for previously purchased equipment.